

PRODUCTGUIDE

BATTERY CHARGERS AND ACCESSORIES



MAXIMUM BATTERY PERFORMANCE



MAXIMIZING BATTERY PERFORMANCE



CONTENTS

EASY CHARGING 4

CONSUMER CHARGERS 5

PROFESSIONAL CHARGERS 15

INTEGRATED SOLUTIONS 23

ACCESSORIES 35

EASY CHARGING

STEP BY STEP

CTEK Chargers maximise the life of your battery through a series of 4 to 8 steps in a unique charging process. The chargers constantly monitor the condition of the battery.

When required, they take appropriate action: desulphating, reviving, charging, conditioning and maintaining.

CTEK Chargers regulate the charge voltage to protect sensitive and expensive electronics.

Some CTEK chargers recondition and help revive deeply discharged batteries. Others even have a backup power supply mode, so you can change your vehicle's batteries without losing any program settings. Once the charger is connected, you can forget about how long the battery needs to be charged or whether it is sulphated. Our chargers take care of all this automatically. We call it "Connect and Forget".

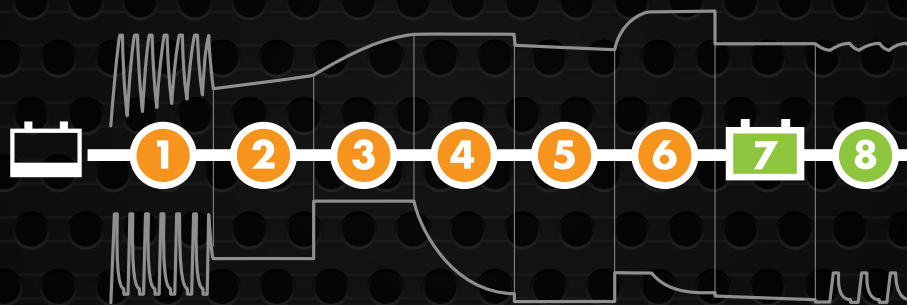

1 STEP 1 **DESULPHATION**

Pulsing voltage removes sulphates from the lead plates in the battery and restores battery capacity.

2 STEP 2 **SOFT START**

Tests if the battery can take charge. Charging begins if the battery is OK.

3 STEP 3 **BULK**

Charges at maximum current, to approx. 80% of the battery capacity.

4 STEP 4 **ABSORPTION**, Ready for use

Charges at declining current until the battery has reached 100% of battery capacity.

5 STEP 5 **ANALYZE**

Tests if the battery can hold charge. Batteries that cannot hold charge may need replacement.

6 STEP 6 **RECOND**

Reconditioning function for deeply discharged batteries.

7 STEP 7 **FLOAT (maintenance)**,

Fully charged

Maintains the battery voltage at maximum level by providing a constant voltage charge.

8 STEP 8 **PULSE**, Maintenance charging

Maintains the battery at 95-100 % capacity. The charger monitors the battery voltage and gives a pulse when necessary, to keep the battery fully charged.

CONSUMER

Modern cars are full of electronics, and demands on batteries are increasing all the time. One day the battery won't be able to power the electronics, and you might not even get started. With a CTEK charger you don't have to worry, no matter what adventures await you!





CT5 START/STOP

PART NO. 40-107

The CT5 START/STOP battery charger is specially designed to provide safe and easy charging and maintenance for vehicles equipped with new generation Start/Stop technology. There are no buttons that need pressing or settings to choose. This easy to use smart charger is the perfect solution for keeping your AGM or EFB battery in peak health to maximize vehicle performance, extend battery life and help reduce your CO₂ emissions.

FEATURES

- FULLY OPTIMISED FOR START/STOP BATTERY TYPES I.E. AGM AND EFB BATTERIES.
- SIMPLE TO USE WITH AN EASY TO UNDERSTAND DISPLAY.
- FULLY AUTOMATIC CHARGING.
- NON-SPARKING, REVERSE-POLARITY PROTECTED.



TECHNICAL DATA

Voltage	14.55 V
Charging current	3.8 A
Charger type	Multi Step fully automatic charging cycle
Battery type	12V AGM and EFB lead-acid batteries
Battery capacity	14-110 Ah, maintenance charging up to 130 Ah
Insulation	IP65 (splash and dust proof)
Warranty	5 year warranty





CT5 TIME TO GO

PART NO. 40-161

CT5 TIME TO GO puts you in the picture by giving an answer to the questions “when can I try and start my vehicle after a flat battery” and “how long before my battery is charged?” CTEK can now give all car-owning consumers exactly what they want – the ability to plan their day.

FEATURES

- FOR ALL TYPES OF LEAD-ACID 12V BATTERIES (WET; MF; CA/CA; AGM AND GEL).
- TELLS YOU HOW LONG BEFORE THE BATTERY IS CHARGED AND READY TO GO.
- INDICATOR TO TELL YOU WHEN YOU CAN TRY AND START THE BATTERY AFTER A FLAT BATTERY.
- FULLY AUTOMATIC CHARGING WITH MAX 5A.
- TESTS AND RESTORES BATTERY CAPACITY.
- NON-SPARKING, REVERSE POLARITY PROTECTED.



TECHNICAL DATA

Voltage	NORMAL 14.4V, AGM 14.7V, RECOND 15.8V
Charging current	Max 5A
Charger type	Multi Step fully automatic charging cycle
Battery type	All types of 12V lead-acid batteries (WET, MF, Ca/Ca and GEL).
Battery capacity	20-160Ah
Insulation	IP65 (splash and dust proof)
Warranty	5 year warranty





CT5 POWERSPORT

PART NO. 40-136

The CT5 POWERSPORT charger is easy to use and works with all powersport vehicle batteries. Connect the CT5 POWERSPORT charger direct to the battery or via the 12V CANBUS socket (compatible with BMW motorcycles) using the INDICATOR PLUG 12V accessory.

FEATURES

- FOR ALL POWERSPORT VEHICLES WITH 12V BATTERIES.
- 2.3A OF POWER, JUST RIGHT FOR CHARGING POWERSPORT VEHICLE BATTERIES.
- MAINTENANCE CHARGING FOR SEASONAL POWERSPORT VEHICLES STORED FOR LONG PERIODS OF TIME.
- ENABLES CHARGING ON BMW MOTORCYCLES USING CANBUS TECHNOLOGY.
- NON-SPARKING, REVERSE-POLARITY PROTECTED.



Enable charging on BMW motorcycles using CANBUS technology.



TECHNICAL DATA

Voltage	NORMAL 14.4V, AGM 14.7V, RECOND 15.8V
Charging current	Max 2.3A
Charger type	Multi Step fully automatic charging cycle
Battery type	All types of 12V lead-acid batteries (WET, MF, Ca./Ca, AGM and GEL)
Battery capacity	5-25 Ah
Insulation	IP65 (splash and dust proof)
Warranty	5 year warranty



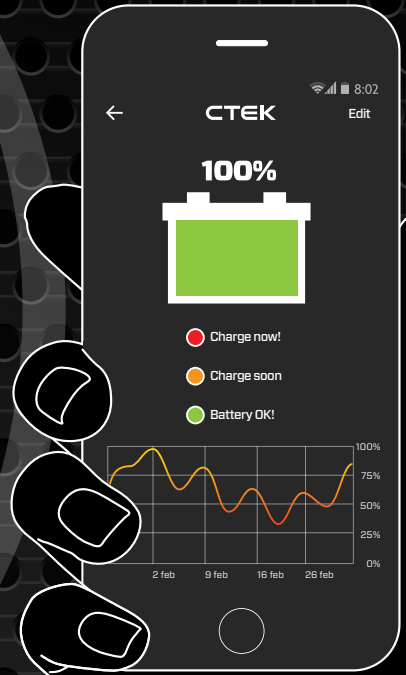

BATTERY SENSE SMART BATTERY HEALTH MONITOR

Prevent breakdowns. Easily track the health of your battery with this unique Bluetooth enabled smart tracking device. It's easy to install and data is delivered through free to download iPhone or Android App.



Compatible with:
Android OS 4.4 (or higher) and Bluetooth 4.0 hardware.
iOS 7 (or higher) and Bluetooth 4.0 hardware (iPhone 4S or newer).

CTX BATTERY SENSE

PART NO. 40-149

Take control of your battery's health. Simply connect the Battery Sense monitor and download the free App.

FEATURES

- SUITABLE FOR ALL LEAD-ACID BATTERIES FROM 5 TO 200AH.
- CONTINUOUSLY MEASURES THE BATTERY TO PROVIDE INFORMATION ABOUT BATTERY HEALTH.
- SYNC STATS AUTOMATICALLY VIA BLUETOOTH TO YOUR MOBILE PHONE.
- SIMPLE TO UNDERSTAND CONDITION REPORT ON YOUR VEHICLE'S BATTERY.
- STORES UP TO THREE MONTHS OF STATS.
- NOTIFICATIONS IF BATTERY'S STATE OF CHARGE FALLS TO A CRITICAL LEVEL OR IF MEASUREMENTS NOT TAKEN FOR SEVEN DAYS.
- 2-YEAR WARRANTY.



TECHNICAL DATA

Rated voltage DC	7.0-16VDC
Min battery voltage	7.0VDC
Max current consumption	Less than 1mA @ 12.5V
Ambient temperature	-30°C to +85°C
Battery types	12V lead-acid batteries
Battery capacity	5-200Ah
Insulation	IP67
Warranty	2 year warranty

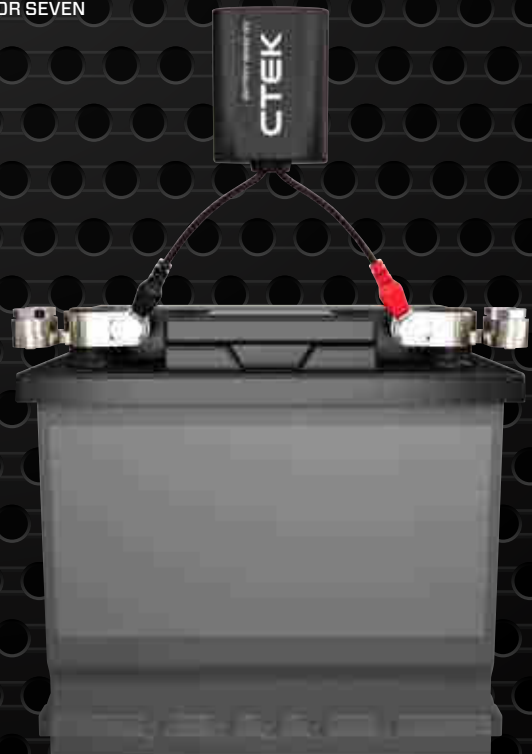

XC 0.8



PART NO. 56-729

The XC 0.8 is the charger that can give your vintage car a new lease of life. It is a complete 6 V battery charger in a small format that charges everything from small batteries of 1 Ah up to the larger tractor batteries.

- Fully automatic charging and maintenance in 4 steps maximizes battery life and performance.
- Compact tough design – splash resistant and dustproof to IP65.
- Patented maintenance charge for a unique combination of maximized life and performance.
- Patented desulphation that extends the battery life.
- No sparks, short-circuit proof and reverse-polarity protected for trouble-free usage.

TECHNICAL DATA

Voltage	7.2 V
Charging current	0.8 A
Charger type	4 step, fully automatic charging cycle
Battery type	6 V lead-acid batteries
Battery capacity	1.2-100 Ah
Insulation	IP65 (splash and dust proof)
Warranty	5 year warranty



XS 0.8



PART NO. 56-707

The XS 0.8 offers state of the art technology and is perfect for charging smaller 12 V batteries that can be found in motorcycles, jet skis, ATVs and lawnmowers. It is also suitable for maintenance charging 'normal size' batteries such as car batteries. The unique display allows the user to follow the entire charging process. The XS 0.8 is designed to protect vehicle electronics. It is non-sparking, reverse polarity protected and short-circuit proof.

- Charges batteries up to 32 Ah. Maintains larger batteries up to 100 Ah.
- Fully automatic, 6 step charging includes patented desulphation and pulse maintenance programs.
- Compact tough design – splash resistant and dustproof to IP65.

TECHNICAL DATA

Voltage	14.4 V
Charging current	Max 0.8 A
Charger type	6 step, fully automatic charging cycle
Battery type	12 V lead-acid batteries
Battery capacity	1.2-32 Ah, maintenance charging up to 100 Ah
Insulation	IP65 (splash and dust proof)
Warranty	5 year warranty



MXS 3.8



PART NO. 56-309

The MXS 3.8 is a microprocessor controlled battery charger with patented Float/Pulse maintenance. The MXS 3.8 solves a broad range of battery problems and is the ideal charger for everyday use. The MXS 3.8 tests the battery condition before charging to establish if it can receive and retain charge. The MXS 3.8 features a patented automatic desulphation phase during the charging process. A special 'Snowflake' mode for optimum charging on cold winter days. The patented Float/Pulse maintenance means the MXS 3.8 is ideal for long-term maintenance. The entire charging process is easily followed on the clear LED display.

- Charges batteries up to 85 Ah. Maintains larger batteries up to 130 Ah.
- Unique 7 step charging.
- Cold weather mode.
- Connect and Forget.
- Extends battery life.

TECHNICAL DATA

Voltage	14.4/14.7 V
Charging current	Max 3.8 A
Charger type	7 step, fully automatic charging cycle
Battery type	All 12 V Lead Acid types
Battery capacity	1.2-85 Ah, maintenance charging up to 130 Ah
Insulation	IP65 (splash and dust proof)
Warranty	5 year warranty



MXS 5.0



PART NO. 56-305

The MXS 5.0 is a microprocessor controlled battery charger with automatic temperature sensor built-in. The MXS 5.0 solves a broad range of battery problems and is the ideal charger for the user with high demands. The MXS 5.0 tests whether the battery can retain a charge. The MXS 5.0 offers a patented automatic desulphation phase and a specific program for reconditioning, reviving and restoring deeply discharged and stratified batteries. AGM mode is perfect for maximising performance and life of most Start/Stop batteries.

- Charges batteries up to 110 Ah. Maintains larger batteries up to 160 Ah.
- Unique 8 step charging.
- Temperature sensor.
- AGM program.
- 8 charging programs/program alternatives.

TECHNICAL DATA

Voltage	14.4/14.7/15.8 V
Charging current	Max 5 A
Charger type	8 step, fully automatic charging cycle.
Battery type	12 V lead-acid batteries
Battery capacity	1.2-110 Ah, maintenance charging up to 160 Ah
Insulation	IP65 (splash and dust proof)
Warranty	5 year warranty

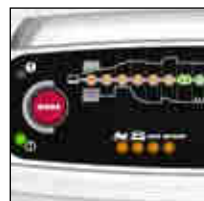

MXS 5.0 POLAR



PART NO. 56-855

The MXS 5.0 POLAR has been specially developed to offer excellent all round charging with special cold weather performance. MXS 5.0 POLAR offers specially adapted cables that handle severe cold down to -30°C . The MXS 5.0 POLAR is an advanced microprocessor controlled battery charger providing unrivalled performance on lead-acid batteries. The 'Snowflake' option ensures ideal charging performance even in the most extreme cold conditions. Patented Float/Pulse maintenance makes the MXS 5.0 POLAR ideal for long-term maintenance.

- Fully automatic charging and maintenance in 8 steps maximizes battery life and performance.
- Compact tough design – splash resistant and dustproof to IP65.
- Patented maintenance charge for a unique combination of maximised life and performance.
- Patented desulphation that extends the battery life.
- No sparks, short-circuit proof and reverse-polarity protected for trouble-free usage.



TECHNICAL DATA

Voltage	14.4/15.0/15.8 V
Charging current	Max 5 A
Charger type	8 step, fully automatic charging cycle.
Battery type	12 V lead-acid batteries
Battery capacity	1.2-110 Ah, maintenance charging up to 160 Ah
Insulation	IP65 (splash and dust proof)
Warranty	5 year warranty

MXS 5.0 TEST&CHARGE



PART NO. 56-308

The MXS 5.0 TEST&CHARGE combines an advanced microprocessor controlled battery charger with a battery and alternator test function to provide the ultimate in battery testing, charging and maintenance.

TESTING – Three easy to use programs to test battery voltage, start power and alternator performance to provide a complete picture of battery and vehicle charging system health.

CHARGING – MXS 5.0 TEST&CHARGE provides excellent charging performance. The charger solves a broad range of battery problems and features include a patented automatic desulphation program and a special reconditioning function that revives and restores deeply discharged and stratified batteries. The patented Float/Pulse maintenance makes the charger ideal for long-term maintenance.



TECHNICAL DATA

Voltage	14.4/14.7/15.8 V
Charging current	5 A
Charger type	8 step, fully automatic charging cycle 3 voltage test programs
Battery type	12 V lead-acid batteries
Battery capacity	1.2-110 Ah, maintenance charging up to 160 Ah
Insulation	IP65 (splash and dust proof)
Warranty	5 year warranty

MXS 7.0



PART NO. 56-731

The MXS 7.0 is the perfect universal 12 V charger. It is ideal for charging larger batteries found in caravans, RV's, boats and cars. The MXS 7.0 offers features such as battery diagnosis, a special reconditioning function and unique maintenance charging. The charger even has a mode for optimised charging during cold winter days and the charging of AGM batteries. The MXS 7.0 also has a Supply mode which allows the battery to be disconnected from the vehicle without losing important configurations.

- Charges batteries from 14 Ah up to 150 Ah. Maintains larger batteries up to 225 Ah.
- Supply program – can be used as a 12 V power source to protect electrical settings.
- Cold weather program, for charging in cold conditions and for AGM batteries.
- Recond program – special program to revive deeply discharged batteries.
- Splash resistant and dust-proof to IP65.



TECHNICAL DATA

Voltage	14.4/14.7/15.8/13.6 V
Charging current	Max 7 A
Charger type	8 step, fully automatic charging cycle
Battery type	12 V lead-acid batteries
Battery capacity	14-150 Ah, maintenance charging up to 225 Ah
Insulation	IP65 (splash and dust proof)
Warranty	5 year warranty

MXS 10



PART NO. 56-708

The MXS 10 contains the very latest technology. It is ideal for professional use and excellent in workshops, caravans, RVs, boats or cars. The MXS 10 offers features such as battery diagnosis, a special reconditioning function, unique maintenance charging and a temperature sensor for optimised charging. The special AGM mode is ideal for AGM battery chemistry and where Start/Stop batteries are to be charged or maintained. The charger also has a Supply mode which allows the battery to be disconnected from the vehicle without losing important configurations.

- Charges batteries from 20 Ah up to 200 Ah. Maintains larger batteries up to 300 Ah.
- Recond program – special program to revive deeply discharged batteries.
- Supply program – can be used as a 12 V power source to protect electrical settings.
- Special AGM mode – ideal for Start/Stop batteries.
- Removable temperature sensor.



TECHNICAL DATA

Voltage	14.4/14.7/15.8/13.6 V
Charging current	Max 10 A
Charger type	8 step, fully automatic charging cycle
Battery type	12 V lead-acid batteries
Battery capacity	20-200 Ah, maintenance charging up to 300 Ah
Insulation	IP65 (splash and dust proof)
Warranty	2 year warranty



The LITHIUM XS is an advanced microprocessor controlled charger specially designed to charge and maintain the cells of Lithium-Ion Phosphate (LiFePO₄) batteries - maximising their performance and lifespan. With up to 5 A of charge current available the LITHIUM XS is extremely flexible and will charge LiFePO₄ batteries from 5 Ah to 60 Ah. Operation is simple and charging will commence upon connection. No need to disconnect the battery from the vehicle. At charge start the LITHIUM XS will automatically reset any low voltage protection electronics (Battery Management System) fitted. Charging can be restarted manually at any time using the 'Reset' button.

- Safe and easy to use.
- Designed for LiFePO₄ batteries.
- Automatic low voltage reset.
- Checks battery condition at each stage.
- Ensures maximum battery capacity.

TECHNICAL DATA

Voltage	13.8/14.4 V
Charging current	Max 5 A
Charger type	8 step, fully automatic charging cycle
Battery type	12 V Lithium Ion Phosphate (LiFePO ₄)
Battery capacity	5-60 Ah, maintenance charging up to 120 Ah
Insulation	IP65 (splash and dust proof)
Warranty	5 year warranty

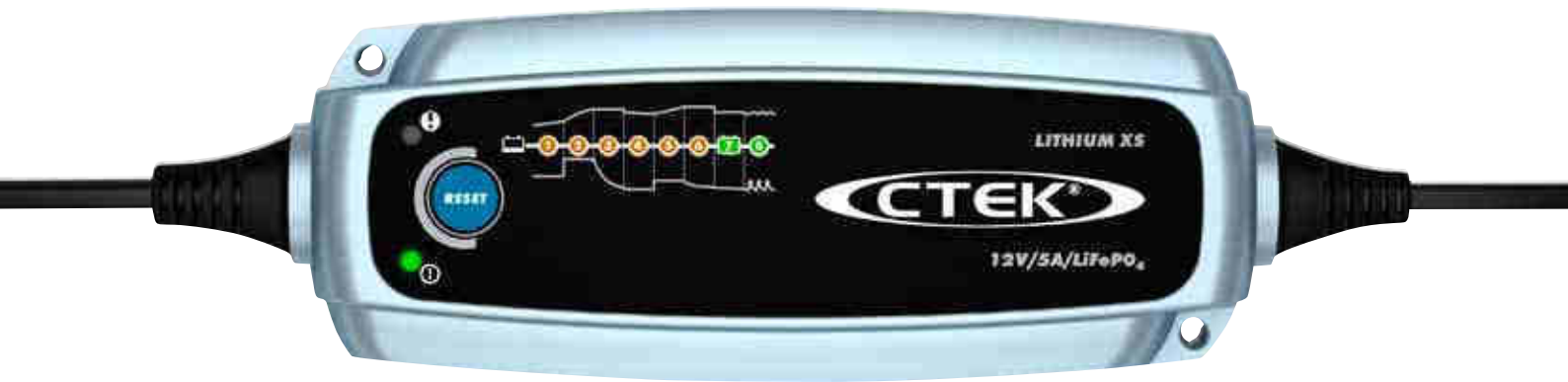

1 STEP1 ACCEPT

Tests if the battery can accept charge. This step prevents charging from proceeding on a defective battery.

2 STEP2 BULK

Charging with maximum current until approximately 90 % battery capacity.

3 STEP3 ABSORPTION

Charging with declining current to maximize up to 95 % battery capacity.

4 STEP4 ANALYZE

Tests whether the battery can retain a charge. Batteries that cannot retain a charge may require replacement.

5 STEP5 COMPLETION

Final charge with reduced current up to approximately 98% battery capacity.

6 STEP6 MAXIMIZATION

Final charge with maximum voltage up to 100% battery capacity.

7 STEP7 FLOAT

Keeps battery voltage at maximum level by charging at a constant voltage.

8 STEP8 PULSE

Maintaining the battery at 95-100% capacity. The charger monitors the battery voltage and gives a pulse when necessary to keep the battery fully charged.

PRO

Battery support during service, diagnostics and flashing requires a safe and stable power supply. The various battery types found in today's vehicles all require safe and effective charging - and sometimes recovery and reconditioning. CTEK Pro Series chargers offer safe, simple to use and effective solutions for all workshop battery support and charging needs.

MXS 10EC



PART NO. 40-095

The CTEK MXS 10EC is a fully automatic 12 V 10 A 8 step smart charger and battery support unit. Designed for workshop use, the MXS 10EC includes a wide range of features, including an automatic diagnostic function that tests whether a battery is able to take and hold a charge and a supply function that allows it to be used as a power supply to support vehicle electronics during sensitive battery changeovers. Temperature compensated for efficiency. The versatile MXS 10EC features 4 metre extended cables and a protective silicon rubber bumper.

- Designed for workshop use.
- Versatile battery diagnostic, charging, reconditioning and support functions.
- Equipped with long 4 metre cables for convenience.
- Highly portable with durable non-slip protective bumper guard.



TECHNICAL DATA

Voltage	14.4/14.7/15.8/13.6 V
Charging current	Max 10 A
Charger type	8 step, fully automatic charging cycle
Battery type	12 V lead-acid batteries
Battery capacity	20-200 Ah, maintenance charging up to 300 Ah
Insulation	IP65 (splash and dust proof)
Warranty	2 year warranty

MXS 25



PART NO. 56-732

The MXS 25 is a professional 12 V charger. It offers efficient and fast charging and is ideal in workshops, caravans, RVs and boats. The MXS 25 is equipped with all necessary features and functions to solve a broad range of battery related problems. It offers features such as battery diagnosis that shows if a battery can receive and retain a charge, a special reconditioning function that restores stratified and deeply discharged batteries, unique maintenance charging, and a temperature sensor for optimised charging regardless of the weather conditions. It also has a Supply mode which allows the battery to be disconnected from the vehicle without losing important configurations.

- Charges and maintains batteries from 40 Ah up to 500 Ah.
- Supply program - can be used as a 12 V power source to protect electrical settings or provide battery support during diagnostics up to 25 A.
- Built-in temperature sensor.
- Reconditioning program.
- IP44 rated, suitable for outdoor use.



TECHNICAL DATA

Voltage	14.4/15.8/13.6 V
Charging current	Max 25 A
Charger type	8 step, fully automatic charging cycle
Battery type	12 V lead-acid batteries
Battery capacity	40-500 Ah, maintenance charging up to 500 Ah
Insulation	IP44 (outdoor use)
Warranty	2 year warranty



The MXS25EC is a fully automatic 8 step smart charger and battery support unit that delivers 25 A to 12 V Batteries from 40-500 Ah. Highly portable the MXS 25EC is a versatile and essential piece of equipment for charging, reconditioning and providing support for batteries in today's professional vehicle workshop. Temperature compensated for efficiency the MXS 25EC comes with 6 metre heavy duty cables and wall hanger.

- Safe and easy to use.
- Tests and reconditions deeply discharged batteries.
- Battery support function.
- Supplied with 6 metre cables, wall hanger and bracket.

TECHNICAL DATA

Voltage	14.4/15.8/13.6 V
Charging current	Max 25 A
Charger type	8 step, fully automatic charging cycle
Battery type	12 V lead-acid batteries
Battery capacity	40-500 Ah up to 500 Ah for maintenance
Insulation	IP44 (outdoor use)
Warranty	2 year warranty



The Battery Analyzer accurately tests the condition of 12V lead-acid starter batteries including Wet, Maintenance Free, Ca/Ca and Gel. Easy to use it provides fast and easy to understand results. The easy to read display gives clear information on the condition of the 12 V lead-acid battery and advises what action is required. With no need to disconnect the battery from the vehicle, the patented technology used by the Battery Analyzer is safe for the user and vehicle electronics. It is reverse polarity protected, creates no battery loads, heat or sparks.

- Simply connect to battery (no need to disconnect) and follow the on-screen instructions.
- Tests the battery in seconds providing an instant on-screen result which advises what action should be taken.
- Patented technology provides fast, accurate results test without placing load on the battery.
- Suitable for most 12 V lead-acid starter batteries between 200 and 1200 EN.

TECHNICAL DATA

Type of analyzer	Conductance
Type of battery analyzed	12 V lead-acid starter batteries (WET, MF, Ca/Ca, GEL)
Testing voltage	Min. 8 V, Max. 15 V
Resolution (V)	0.1 V
Accuracy (V)	± 0.1 V
Range (EN)	200-1200 EN
Accuracy (EN)	± 25 EN
Warranty	2 year warranty





PRO BATTERY TESTER

PART NO. 40-209

The CTEK PRO Battery Tester gives you quick, simple and accurate battery tests in seconds. It has an integrated printer so you can hand your customer a printout of the results and talk to them immediately about preventative maintenance for their battery or electrical system. The patented PRO Battery Tester is ideal for different types of 12V batteries (standard/flooded, AGM and GEL) and electrical systems in cars and light trucks.

FEATURES

- MULTIPLE RATING SYSTEM COMPATIBLE (CCA, DIN, EN, IEC, SAE)
- TESTS MULTIPLE BATTERY CHEMISTRIES: STANDARD/FLOODED, AGM AND GEL
- TESTS 12V BATTERIES AND ELECTRICAL SYSTEMS FOR CARS AND LIGHT TRUCKS
- TESTS STARTING AND CHARGING SYSTEM VOLTAGE
- INTEGRATED PRINTER

TECHNICAL DATA

Display	LCD text display
Temperature compensated	Tester prompted
Operating temperature	0-50° C (32-120° F)
Test range	100-900 CCA 100-550 DIN 100-900 EN 100-550 IEC 100-900 SAE
Built-in printer	Powered by battery under test
Voltage range	Tests 12V batteries down to 1V
Cable length	533.4 mm
Power requirements	Uses power of battery under test or 9V battery
Voltmeter	0.9-16 Vdc, +/- 0.05 Vdc
Housing material	Acid resistant ABS plastic
Dimensions	230 x 102 x 65 (mm)
Weight	499 g



MXTS 40



PART NO. 56-995

The MXTS 40 is essential equipment that is suitable for universal use in the 12 V and 24 V vehicle workshop or showroom. It is a simple to use, electronically safe battery charger with rapid charging capabilities for all chemistries. Equally suited to battery support, the MXTS 40 provides selectable constant voltage settings to avoid ECU damage. Highly portable the MXTS 40 comes with 2.5 metre heavy duty cables and high quality detachable clamps.

- Ideal for workshop and showroom use.
- 40A/12 V and 20A/24 V output.
- Selectable constant voltage power supply for ECU's.
- Temperature compensation and battery reconditioning.
- Heavy duty 2.5 M detachable charge cables and clamps.
- Compatible with Pro Accessories.



TECHNICAL DATA

Voltage	14.4V/14.7 V/15.8 V and 28.8 V/29.4 V/31.6 V
Charging current	Max 40/20 A
Charger type	8 step, fully automatic charging cycle with adjustable parameters
Power supply settings	12V: 13.6V/14.0V/14.4V/14.8V 24V: 27.2V/ 28.0V/28.8V/ 29.6V
Battery type	All types of 12 V/24 V lead-acid batteries
Battery capacity	12V: 20-1200Ah, 24V: 10-600Ah
Insulation	IP20
Warranty	2 year warranty

MXTS 70/50



PART NO. 40-016

The MXTS 70/50 is a powerful workshop charger and battery support unit with advanced features. The MXTS 70/50 is a fully automatic 8 step charger that delivers selectable 50 A/12 V or 24 V to lead-acid batteries from 20-1500 Ah. With 50A of constant power supply in 12V and 24V mode. Additionally, in 12 V mode, up to 70 Amps of power is automatically available for temporary high loads. It is suitable all lead acid-batteries including AGM and EFB Start/Stop types. User friendly, the MXTS 70/50 features LED displays showing the status of charging, charge voltage, current, charge time (h), and energy indication (Ah) to provide clear information on status and progress.

- Ideal for workshop and showroom use - battery support or charging.
- 50A/12 V and 24 V output - charging.
- Constant 50A power supply in 12V/24V - up to 70A in 12V setting.
- Selectable constant voltage power supply for ECU's.
- Temperature compensation and battery reconditioning.
- Heavy duty 6 M detachable charge cables and clamps.
- Compatible with Pro Accessories.



TECHNICAL DATA

Voltage	Max 16/32 V
Charging current	Max 50 A, 70 A (30 sec.) for 12 V, Max 50A 24V
Charger type	8 step, fully automatic charging cycle with adjustable parameters
Battery type	All types of 12 V/24 V lead-acid batteries
Battery capacity	20-1500 Ah
Insulation	IP20
Warranty	2 year warranty

The PRO60 is a new generation advanced charger and battery support unit designed specifically for the needs of the modern 12V vehicle workshop. Highly portable, easy to use and suitable for all Lead -Acid technologies including AGM and EFB Start/Stop types, the PRO60 also features an advanced Lithium charging mode. The Patent Applied For 'Adaptive Charging' function constantly analyses the battery to ensure maximum battery charge is achieved in the shortest possible time and allows the user to easily charge any Lead - Acid battery size from as little as 10Ah capacity. Selectable voltage battery support for workshop or showroom is available - up to 60A constant current.

- All battery types including Lithium.
- Adaptive charging and wide battery range: 10Ah - 1600Ah.
- Selectable 12.6V-14.8V constant voltage output up to 60 Amps.
- 5M DC cables and high specification clamps.
- High efficiency with fan-less cooling.

TECHNICAL DATA

Voltage	14.4V/14.7V/15.8V
Charging current	Max 60 A
Charger type	8 step, fully automatic charging cycle with adjustable parameters and adaptive charging
Battery type	All types of 12V Lead-Acid and Lithium LiFePO4
Battery capacity	Lead-Acid: 10-1800Ah, LiFePO4: 15-600Ah
Insulation	IP40 (indoor use)
Warranty	2 year warranty





NEW!



PRO120

PART NO. 40-230

The PRO120 restores charge and reconditions batteries using a patented multi step charging process. It's compatible with all types of 12V battery, including normal wet/flooded, Ca/Ca and Lithium (LiFePO4), as well as AGM and EFB Stop/Start batteries.

The PRO120's 'Auto-Adaptive charging' mode automatically detects the appropriate settings for the battery and applies the optimum settings for the fastest charge. It's designed to be user friendly with just four buttons and a clear, easy to read LCD display. The PRO120 is the perfect stable power supply, with 12.6-14.8V available in selectable 0.1V increments. This ensures that no damage can occur to sensitive vehicle electronics.

FEATURES

- UP TO TO 120 AMPS OF STABLE POWER WITH FULLY ADJUSTABLE VOLTAGE SETTINGS.
- COMPATIBLE WITH ALL TYPES OF 12V BATTERY, INCLUDING LITHIUM (LIFEPO4).
- SUITABLE FOR BATTERIES FROM 10AH-3600AH (15AH-1200AH LIFEPO4).
- 5M CABLES AND HEAVY DUTY CLAMPS.
- HIGH EFFICIENCY WITH FAN-LESS COOLING.

TECHNICAL DATA

Voltage	14.4V/14.7V/15.8V
Charging current	Max 120 A
Charger type	8 step, fully automatic charging cycle with adjustable parameters and adaptive charging
Battery type	All types of 12V Lead-Acid and Lithium LiFePO4
Battery capacity	Lead-Acid: 10-3600Ah, LiFePO4: 15-1200Ah
Insulation	IP40 (indoor use)
Warranty	2 year warranty

MXT 4.0



PART NO. 56-733

The MXT 4.0 is ideal for maintenance charging of larger fleets with 24 V vehicles, backup systems, industrial cleaning machinery and wheelchairs, etc. The MXT 4.0 is equipped with all necessary features and functions to solve a broad range of battery related problems.

- 4 A output charges batteries from 8 Ah up to 100 Ah and maintains larger batteries up to 250 Ah.
- Fully automatic 8 step charging includes patented desulphation and pulse maintenance programs.
- Recond program – special program to revive deeply discharged batteries.
- Cold weather program, for charging in cold conditions and for AGM batteries.
- Compact tough design – splash resistant and dustproof to IP65.



TECHNICAL DATA

Voltage	28.8/29.4/31.6 V
Charging current	Max 4 A
Charger type	8 step, fully automatic charging cycle
Battery type	24 V lead-acid batteries
Battery capacity	8-100 Ah, maintenance charging up to 250 Ah
Insulation	IP65 (splash and dust proof)
Warranty	2 year warranty

MXT 14



PART NO. 56-734

The MXT 14 is a professional 24 V charger. It is developed for commercial vehicles where the batteries are put under considerable strain and is ideal for buses, trucks and CV workshops. The MXT 14 is equipped with all necessary features and functions to solve a broad range of battery related problems.

- Charges batteries from 28 Ah up to 300 Ah and maintains larger batteries up to 500 Ah.
- Supply program – can be used as a 24 V power source to protect electrical settings.
- Recond program – special program to revive deeply discharged batteries.
- Built-in temperature sensor.
- High efficiency.



TECHNICAL DATA

Voltage	28.8/31.6/27.2 V
Charging current	Max 14 A
Charger type	8 step, fully automatic charging cycle
Battery type	24 V lead-acid batteries
Battery capacity	28-300 Ah, maintenance charging up to 500 Ah
Insulation	IP44 (outdoor use)
Warranty	2 year warranty

INTEGRATED SOLUTIONS

Effective battery management has become more important than ever before, as has the demand for integrated charging solutions that meet ever-increasing power requirements, save space and significantly extend battery life.

Whether it's a fixed installation or a more portable 'plug and go' option, there is a CTEK battery charging solution for you. Our range of 12V & 24V chargers will deliver a complete battery care solution and maximize battery performance.



The XS 3600 is a proven and reliable charger. XS 3600 has no mode button - just plug in the mains and connect the battery cables to start charging. The charger offers important features such as desulphation and maintenance charging. It is the ideal charger for those looking for quality and simple connect and forget charging.

- Charges batteries up to 75 Ah. Maintains larger batteries up to 120 Ah.
- Fully automatic charging and maintenance in 4 steps maximises battery life and performance.
- Patented desulphation that extends battery life.
- No sparks, short-circuit proof and reverse-polarity protected for trouble-free usage.

TECHNICAL DATA

Voltage	14.4 V
Charging current	3.6 A
Charger type	4 Step, fully automatic charging cycle
Battery type	All 12 V Lead Acid types
Battery capacity	7-75 Ah, maintenance charging up to 120 Ah
Insulation	IP65 (splash and dust proof)
Warranty	2 year warranty



The XS 7000 is the perfect universal 12 V charger. XS 7000 has no mode button, just plug in the mains and connect the battery cables to start charging. It is ideal for charging larger batteries and has been developed for either portable operation or permanent mounting. The XS 7000 offers features such as battery diagnosis that shows if a battery can receive and retain a charge, along with unique maintenance charging.

- Charges batteries from 14 Ah up to 150 Ah. Maintains larger batteries up to 225 Ah.
- No sparks, short-circuit proof and reverse-polarity protected for trouble-free usage.
- Automatic detection of end-of-life batteries that eliminates unwanted surprises.
- Splash resistant and dust-proof to IP65.

TECHNICAL DATA

Voltage	14.4 V
Charging current	Max 7 A
Charger type	7 step, fully automatic charging cycle
Battery type	12 V lead-acid batteries
Battery capacity	14-150 Ah, maintenance charging up to 225 Ah
Insulation	IP65 (splash and dust proof)
Warranty	2 year warranty



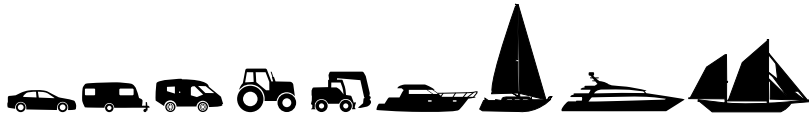

The XS 25000 is a professional 12 V charger. It offers efficient and fast charging and is ideal for charging and maintenance charging of 12 V vehicles and machinery. The XS 25000 is equipped with all necessary features and functions to solve a broad range of battery related problems. It offers features such as battery diagnosis that shows if a battery can receive and retain a charge, unique maintenance charging, and a temperature sensor for optimised charging regardless of the weather conditions.

- Temperature compensated and fully automatic charging and maintenance.
- Patented desulphation that extends battery life.
- No sparks, short-circuit proof and reverse-polarity protected for trouble-free usage.
- Automatic detection of end-of-life batteries that eliminates unwanted surprises.



TECHNICAL DATA

Voltage	14.4 V
Charging current	Max 25 A
Charger type	7 step, fully automatic charging cycle
Battery type	12 V lead-acid batteries
Battery capacity	40-500 Ah, maintenance charging up to 500 Ah
Insulation	IP44 (outdoor use)
Warranty	2 year warranty







D250SA

PART NO. 40-186

With award winning Swedish technology, the dual input D250SA allows you to enjoy your vehicle more with maximized battery capacity as the ideal charger for vehicles without access to a mains power supply.

FEATURES

- 5 STEP CHARGING FROM SMART AND CONVENTIONAL ALTERNATORS AND DC SOURCES, SUCH AS SOLAR AND WIND
- AUTOMATIC BATTERY SEPARATOR WORKS WITHOUT THE NEED FOR DIODES OR VSR RELAYS
- SELECTABLE AGM MODE FOR AGM BATTERIES
- PARALLEL INPUT FROM BOTH ALTERNATOR AND SOLAR PANEL
- SOLAR PANEL REGULATOR WITH MAXIMUM POWER POINT TRACKING (MPPT)
- STARTER BATTERY MAINTENANCE CHARGING WHEN YOUR SERVICE BATTERY IS FULLY CHARGED

TECHNICAL DATA

Voltage	Max 14.4V (14.7V in AGM)
Charging current	20 A
Charger type	5 step, fully automatic charging cycle
Battery type	12 V lead-acid batteries
Battery capacity	40-300 Ah
Insulation	IP65 (splash and dust proof)
Warranty	2 year warranty



SMARTPASS 120

PART NO. 40-185

Smartpass 120 charges and supplies the service battery and equipment with 120A, separates critical equipment from non-critical equipment ensuring that radio, emergency lights and navigation systems always have power.

FEATURES

- AUTOMATIC BATTERY SEPARATOR WORKS WITHOUT THE NEED FOR DIODES OR VSR RELAYS
- BATTERY GUARD MAKES SURE THAT CRITICAL FUNCTIONS ALWAYS HAVE POWER AND PROTECTS YOUR SERVICE BATTERY FROM TOTAL DISCHARGE
- START ASSISTANCE USES POWER FROM YOUR SERVICE BATTERY TO HELP GET YOUR ENGINE STARTED IF YOUR STARTER BATTERY IS FLAT
- CURRENT SOURCE PRIORITY SUPPLIES POWER TO CRITICAL EQUIPMENT DIRECTLY FROM THE ALTERNATOR WHEN THE ENGINE IS RUNNING
- STARTER BATTERY MAINTENANCE CHARGING WHEN YOUR SERVICE BATTERY IS FULLY CHARGED

TECHNICAL DATA

Charging current	120 A (350A temporarily for 10 seconds)
Battery type	12V lead-acid batteries
Battery capacity	28-800 Ah
Insulation	IP65 (splash and dust proof)
Warranty	2 year warranty



140A OFF ROAD CHARGING SYSTEM

PART NO. 40-257

CTEK has created the ultimate 12V power system for your vehicles by combining the D250SA Charger and a SMARTPASS 120 Complete Management Unit.

Installing these products into your 4WD, camper trailer or caravan will give your batteries the ultimate performance, power and lifespan. CTEK enables you to extend your enjoyment of the outdoors!

D250SA

The D250SA charger obtains its energy from DC sources such as alternators, solar panels or wind power and optimizes this power to meet the charging requirements of different battery banks.

SMARTPASS 120

SMARTPASS 120 is an energy management unit with built-in undervoltage protection. It utilizes the available energy and supplies it to the service batteries or the electrical loads.

SYSTEM MONITOR

The unit continually monitors the voltage, the current (charge and discharge) and calculates the state of charge together with the time remaining to charge or discharge the battery.

20A OFF GRID CHARGING SYSTEM

PART NO. 40-256

CTEK charging system charges your battery bank from several sources, prioritizes connections, and looks after the battery so it will not become completely flat. It also optimizes charging while driving to give you more time off-grid. CTEK gives you full control with the battery monitor that shows you how many hours are left before the battery bank is empty. With this system you can sit back and relax because you know how long your battery will last.

D250SA

The D250SS charger obtains its energy from DC sources such as alternators, solar panels or wind power and optimizes this power to meet the charging requirements of different battery banks.

SYSTEM MONITOR

The unit continually monitors the voltage, the current (charge and discharge) and calculates the state of charge together with the time remaining to charge or discharge the battery.





XT 14000



PART NO. 40-139

The XT 14000 is a professional 24V charger. It has been developed for charging and maintenance charging of 24V vehicles and machinery. The XT 14000 is equipped with all necessary features and functions to solve a broad range of battery related problems. It offers features such as battery diagnosis that shows if a battery can receive and retain a charge, unique maintenance charging, and a temperature sensor for optimised charging regardless of the weather conditions.

- No mode button - just plug in the mains and connect the battery cables to start charging.
- Compact tough design - IP44 rated, suitable for outdoor use.
- Temperature sensor.
- Automatic detection of end-of-life batteries that eliminates unwanted surprises.

TECHNICAL DATA

Voltage	28.8 V
Charging current	Max 14 A
Charger type	7 step, fully automatic charging cycle
Battery type	24 V lead-acid batteries
Battery capacity	28-300 Ah, maintenance charging up to 500 Ah
Insulation	IP44 (outdoor use)
Warranty	2 year warranty



XT 14000 EXTENDED



PART NO. 40-140

The XT14000 EXTENDED is a professional 24 V charger. It is developed for charging and maintenance charging of 24 V vehicles and machinery. XT14000 EXTENDED has no mode button, just plug in main and connect battery cables to start charging.

- No mode button - just plug in the mains and connect the battery cables to start charging.
- Compact tough design - IP44 rated, suitable for outdoor use.
- Temperature sensor.
- Automatic detection of end-of-life batteries that eliminates unwanted surprises.
- 6 m cable and M8 ring terminals for permanent installation.

TECHNICAL DATA

Voltage	28.8 V
Charging current	Max 14 A
Charger type	7 step, fully automatic charging cycle
Battery type	24 V lead-acid batteries
Battery capacity	28-300 Ah, maintenance charging up to 500 Ah
Insulation	IP44 (outdoor use)
Warranty	2 year warranty





The D250TS is a fully automatic battery charger, battery separator and an equaliser for 24 V battery banks combined. Perfect for heavy vehicles, recreational vehicles and boats. The D250TS is a fully automatic 4 step charger that supplies 10 A to 24 V batteries of 28-200 Ah. The charger is IP65 classified and protects vehicle electronics. It is suitable for all types of lead-acid batteries (Wet, MF, Gel, AGM).

- Automatic battery separation.
- IP65 rated – splash and dustproof.
- Input voltage 14–30 V DC; 28.8 V charge voltage.
- Max charge current 10 A; charges batteries 28 Ah to 200 Ah.
- 10 day float/pulse maintenance for maximum charge level.
- High efficiency.



TECHNICAL DATA

Voltage	28.8 V
Charging current	Max 10 A
Charger type	4 step, fully automatic DC/DC charger
Battery type	24 V lead-acid batteries
Battery capacity	28-200 Ah
Insulation	IP65 (splash and dust proof)
Warranty	2 year warranty





M45 is a high quality 4 step charger with unique functions such as desulphating and safe maintenance charging during the winter months.

- Charges batteries from 7 Ah up to 75 Ah and maintains larger batteries up to 120 Ah.
- Compact tough design – splash resistant and dustproof to IP65.
- Selectable charging power to match smaller or larger batteries.
- Optional cold weather / AGM mode.



TECHNICAL DATA

Voltage	14.4/14.7 V
Charging current	0.8 A, 3.6 A
Charger type	4 step, fully automatic charging cycle
Battery type	12 V lead-acid batteries
Battery capacity	7-75 Ah, maintenance charging up to 120 Ah
Insulation	IP65 (splash and dust proof)
Warranty	5 year warranty



The M100 is a fully automatic 8 step charger that supplies 7 A and is ideal for charging batteries between 14 and 150 Ah and up to 225 Ah for maintenance charging.

- Charges batteries from 14 Ah up to 150 A and maintains larger batteries up to 225 Ah.
- Compact tough design – splash resistant and dustproof to IP65.
- Optional cold/AGM program – more efficient charging for AGM batteries and in winter temperatures.
- Supply program – can be used as a 12 V power source to protect electrical settings.
- Recond program – special program to revive deeply discharged batteries.



TECHNICAL DATA

Voltage	14.4/14.7/15.8/13.6 V
Charging current	Max 7 A
Charger type	8 step, fully automatic charging cycle
Battery type	12 V lead-acid batteries
Battery capacity	14-150 Ah, maintenance charging up to 225 Ah
Insulation	IP65 (splash and dust proof)
Warranty	5 year warranty

M200



PART NO. 56-220

M200 is a perfect 15 A battery charger for all boat, motor home and caravan owners. The M200 has a four metre long secondary cable and a temperature sensor for optimised charging irrespective of temperature, which gives extra flexibility in permanent installations. The M200 reconditions stratified batteries with the special Recond program – a regular need in the marine environment where deep cycling of batteries is usual. Can be used in parallel with M200 or M300 for more current.

- Charges batteries from 28 Ah up to 300 Ah and maintains larger batteries up to 500 Ah.
- The Analysis step checks if battery can hold charge.
- Silent night program.
- Compact tough design – IP44 rated, suitable for outdoor use.

TECHNICAL DATA

Voltage	14.4/15.8 V
Charging current	Max 15 A
Charger type	8 step, fully automatic charging cycle
Battery type	12 V lead-acid batteries
Battery capacity	28-300 Ah, maintenance charging up to 500 Ah
Insulation	IP44 (outdoor use)
Warranty	5 year warranty



M300



PART NO. 56-298

M300 is the recommended charger for boats with larger service batteries. The M300 has a four metre long secondary cable and a temperature sensor for optimised charging irrespective of temperature, which gives extra flexibility in permanent installations. M300 is a perfect 25 A battery charger for all boat, motor home and caravan owners. Can be used in parallel with M200 or M300 for more current.

- Charges and maintains marine batteries from 40 Ah up to 500 Ah.
- 10 day float/pulse maintenance for maximum charge level.
- Recond program – restores deeply discharged batteries.
- Silent night program.
- Compact tough design – IP44 rated, suitable for outdoor use.

TECHNICAL DATA

Voltage	14.4/15.8/13.6 V
Charging current	Max 25 A
Charger type	8 step, fully automatic charging cycle
Battery type	12 V lead-acid batteries
Battery capacity	40-500 Ah
Insulation	IP44 (outdoor use)
Warranty	5 year warranty





The I2420 has 15 on board charging curves which can be freely combined together and features automatic reconditioning for deeply discharged batteries using a special charging algorithm, Drive Off protection and integration for NC and NO contacts. The I2420 also has intelligent cable loss compensation for even faster charging and uses advanced technology for its high frequency switch mode. With conversion efficiency up to 94%, the I2420 means low CO₂ emissions and lower power usage in general.

- 15 on board charging curves
- IP64 rated
- Suitable for all standard lead acid, AGM and GEL batteries from as low as 0.5V
- Drive Off protection
- Automatic reconditioning for deeply discharged batteries

TECHNICAL DATA

Input voltage (Mains voltage)	230Vrms ± 10%
Power factor	=1
Conversion efficiency	Up to 94%
Nominal battery voltage	24V
Charge Current	20A
Ripple Voltage*	<100mVpp
Insulation	IP64
Warranty	2 year warranty
Size of charger in mm	197x148x64

*Charging old battery with 40% capacity.



The I2440 has 15 on board charging curves which can be freely combined together and features automatic reconditioning for deeply discharged batteries using a special charging algorithm, Drive Off protection and integration for NC and NO contacts. The I2440 also has intelligent cable loss compensation for even faster charging and uses advanced technology for its high frequency switch mode. With conversion efficiency up to 94%, the I2440 means low CO₂ emissions and lower power usage in general.

- 15 on board charging curves
- IP64 rated
- Suitable for all standard lead acid, AGM and GEL batteries from as low as 0.5V
- Drive Off protection
- Automatic reconditioning for deeply discharged batteries

TECHNICAL DATA

Input voltage (Mains voltage)	230Vrms ± 10%
Power factor	=1
Conversion efficiency	Up to 94%
Nominal battery voltage	24V
Charge Current	40A
Ripple Voltage*	<100mVpp
Insulation	IP64
Warranty	2 year warranty
Size of charger in mm	281x235x85

*Charging old battery with 40% capacity.



ACCESSORIES

Our products are designed and developed to be as simple as possible to use. All CTEK chargers with output up to 10A are supplied with quick connector, COMFORT CONNECT. There are several smart accessories for our quick connector, COMFORT CONNECT, to make battery care even easier. Connect with our smart accessories!

ACCESSORIES CTX



CONNECT EXTENSION

This extension cable allows the CTEK charger to be used further away from the vehicle or battery.

Part no. 40-134



INDICATOR EYELET M8

Practical for those batteries that are difficult to access. Shows the battery's charge level simply and clearly.

Part no. 40-133



INDICATOR PLUG 12V

INDICATOR PLUG 12V can be attached to the CT5 POWERSPORT charger to enable CANBUS charging of BMW motorcycles.

Part no. 40-165

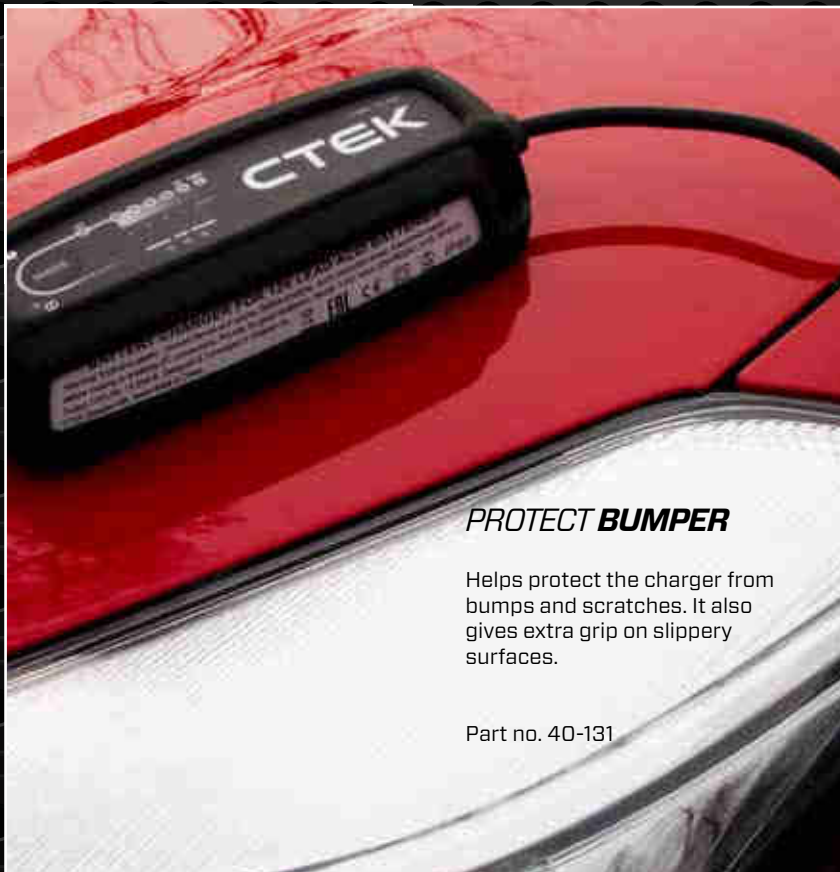

PROTECT BUMPER

Helps protect the charger from bumps and scratches. It also gives extra grip on slippery surfaces.

Part no. 40-131



MOUNTING BRACKET

Robust and versatile mounting bracket for practical charger and cable storage.

Part no. 40-132

COMFORT CONNECT



COMFORT CONNECT - Eyelet

Comfort Connect - Eyelet is a handy accessory that enables you to charge batteries that are in hard to reach places or where using clamps is inconvenient or impossible. Comfort Connect - Eyelet is easy to fit, splash proof and dust proof. 400 mm cable length. Compatible with all CTEK chargers up to 10 A.

Eyelet M6 Part no. 56-260
Eyelet M8 Part no. 56-261
Eyelet M10 Part no. 56-329



COMFORT CONNECT - Cig Plug

Comfort Connect - Cig Plug is an easy to fit adapter that allows charging from a CTEK compatible charger through the 12V cigarette lighter or accessory socket. 400 mm cable length. Compatible with all CTEK chargers up to 10 A.

Note: Socket must be powered even when ignition is in "off" position.

Part no. 56-263



COMFORT CONNECT - Cig Socket

Comfort Connect - Cig Socket is a useful accessory that increases the usage of the CTEK Comfort Connect battery connector. When the COMFORT CONNECT - Cig Socket has been connected, it allows you to use GPS, mobile phones, handlebar heaters and heated clothing etc. 1 m cable length.

Part no. 56-573



COMFORT CONNECT - 2.5 m Extension Cable

Useful extension cable which allows any CTEK charger up to 10 A to be connected to other accessories such as clamps or quick connectors (Comfort Connect). Handy when charger has to be placed some distance from the battery. 2.5 m cable length.

Part no. 56-304



COMFORT CONNECT - Socket Adapter

Adapter which allows 'old style' connectors to be converted to accept connections and accessories from any current CTEK charger up to 10 A. Eliminates the need to change connections to batteries when upgrading the charger. Cable length 120 mm.

Part no. 56-344



COMFORT CONNECT - Plug Adapter

Adapter which allows older (pre 2008) models of CTEK chargers to be compatible with the 'new generation' accessories. Just connect to the CTEK charger fitted with the 'old style' connector and the unit immediately becomes ready for use with all our accessories. Cable length 120 mm.

Part no. 56-689

COMFORT INDICATOR



COMFORT INDICATOR - Eyelet

Comfort Indicator - Eyelet M6 and M8 use a simple 'traffic light' system to show the state of charge of your battery. With Comfort Indicator - Eyelet you have a permanent installation. Should charging be required plug in the CTEK charger and charge the battery. Cable length 500 mm.

Eyelet M6 Part no. 56-629
Eyelet M8 Part no. 56-382



COMFORT INDICATOR - Cig Plug

Comfort Indicator - Cig Plug is a combined quick connector and indicator for easy charging. Perfect for checking status and charging the battery through the vehicle 12 V socket. Suitable for all 12 V CTEK chargers up to 7 A. Comfort Indicator - Cig Plug is a universal model that fits both 12 mm and 21 mm sockets.

Note: Socket must be powered even when ignition is in "off" position.

Part no. 56-870



COMFORT INDICATOR - Clamp

Comfort Indicator - Clamp uses a simple 'traffic light' system to show the state of charge of your battery. Easy to move between vehicles, - ideal for workshops and show-rooms. Should charging be required the cap can be removed from the unit and a compatible CTEK charger plugged in to restore the battery to fully charged status. Cable length 1.5 m.

Part no. 56-384



COMFORT INDICATOR

Comfort Indicator is the easiest way to monitor the charge in your battery. An accurate reading for your battery is displayed two hours after you've used your vehicle.

RED means the battery charge is below 12.4 V. It's definitely time to charge the battery.

YELLOW means the battery charge is between 12.4 and 12.65 V. It's time to start thinking about charging the battery.

GREEN means the battery charge is more than 12.65 V. OK! No need for charging.



COMFORT INDICATOR - Panel

Comfort Indicator - Panel uses a simple 'traffic light' system to show the state of charge of your battery. Available in two cable lengths, 1.5 m and 3.3 m. No cables are included in the Comfort Indicator - Panel with flat pin connection.

Panel M8 (1.5m) Part no. 56-380
Panel M8 (3.3m) Part no. 56-531
Panel (Flat Pin) Part no. 56-562

ACCESSORIES

CTEK BUMPER - 10, 60, 100, 120

CTEK BUMPER helps protect your CTEK charger from bumps and scratches. Adds extra grip on slippery surfaces. Made of durable silicon rubber material. The CTEK BUMPER fits snugly around the body of your CTEK charger.

CTEK BUMPER 10 Suitable for all CTEK chargers 0.8 A. Part no. 40-057	CTEK BUMPER 100 Suitable for all CTEK chargers 7.0 A. Part no. 40-058
---	--

CTEK BUMPER 60 Suitable for all CTEK chargers 3.8-5.0 A. Part no. 56-915	CTEK BUMPER 120 Suitable for all CTEK chargers 10 A. Part no. 40-059
--	---



CTEK BUMPER 10



CTEK BUMPER 60



CTEK BUMPER 100



CTEK BUMPER 120

CTEK MOUNTING BRACKET

Robust and versatile mounting bracket for practical charger and cable storage. Open frame design allows easy access to charger functions.

- Practical storage of charger and cables
- Open frame design allows easy access to charger functions.
- Suitable for all CTEK chargers 3.8-5.0 A



Part no. 40-006



NEW!

EXTERNAL LED CABLE - 2.5M

Cable for remote LED indication of charging status. Perfect for monitoring the status when the charger is installed where not visible.

Suitable for I2420 and I2440.

Part no. 40-229

PRO ACCESSORIES



COMFORT CONNECT - XLR

Comfort Connect - XLR is a useful accessory that allows you to connect the CTEK MXT 4.0 charger easily and directly to the XLR socket found on many 24 V powered wheelchairs and mobility scooters. 3 Pin XLR connection, 400 mm cable length.

Compatible with CTEK MXT 4.0 (4 A).

Part no. 56-867



BUMPER 300

CTEK BUMPER helps protect your CTEK charger from bumps and scratches. Adds extra grip on slippery surfaces. Made of durable silicon rubber material. The CTEK BUMPER fits snugly around the body of your CTEK charger.

Suitable for CTEK chargers MXS15, MXS25, MXS25EC, MXT14, M200, M300

Part no. 40-060



WALL HANGER 300

WALL HANGER 300 (wall hanger) has been specially designed to allow the larger CTEK chargers to be mounted on wall, ramp posts or hung off vehicle doors. The WALL HANGER 300 comprises a plate that can be attached directly to the back of the charger (screws provided) with a hook for safely storing cables. A mounting plate, BRACKET, is included and can be mounted on walls or ramp posts. The wall hanger has rubber feet to avoid scratching vehicle paintwork.

Suitable for use with:
MXS 25, MXT 14, M200, M300

Part no. 56-314



WALL HANGER PRO

WALL HANGER PRO has been specially designed for easier handling and storage of CTEK MXTS 40 or MXTS 70/50. WALL HANGER PRO allows the charger to be mounted on the wall using the enclosed mounting plate, bracket, or to be carried around thanks to the strap. The rubber coated frame protects against scratches and makes it steadier.

Suitable for use with:
MXTS 40, MXTS 70/50

Part no. 40-068



WALL HANGER PRO 60

PRO 60 WALL HANGER allows tidy cable and clamp storage.

Suitable for use with:

- PRO 60

Part no. 40-187



TROLLEY PRO

The TROLLEY PRO is designed to carry a wide range of charging and testing equipment safely. Its tough, black powder coated steel frame and four wheels make the TROLLEY PRO easily manoeuvrable – even in small spaces – but the two wheel brakes keep it firm and still while you're using it. Plus, there are plenty of hooks for neat cable storage and its versatile, pre-drilled panel lets you mount your preferred CTEK pro charger combination right where you want it.

- Versatile test station for charger, testers and batteries.
- Perfect for Flash programming/updating.
- Pre drilled panel to mount multiple CTEK Pro charger combinations.
- Robust steel construction with four wheels.
- Durable black, powder coated finish.

Suitable for use with:

MXS 25, MXT 14, MXTS 40, MXTS 70/50,
PRO60 (with Trolley Adapter - Art No 40-227)
PRO60/PRO120 (with Trolley Adapter – Art No 40-246)

Part no. 56-604

SPARE PARTS

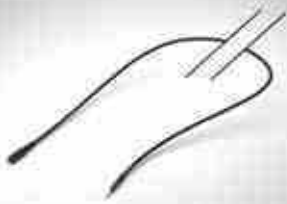

NTC CABLE - 1.7M

1.7 metre temperature sensor cable.

Suitable for:
MXS 10

2 year warranty.

Part no. 40-141



CLAMP SHELLS - Red & Black

Replacement positive and negative terminal clamp shell set.

Suitable for:
MXS 10EC, MXS 15, MXS 25,
MXS 25EC, XS 25000, MXT 14,
Multi XT 14000 Extended, XT 14000

2 year warranty.

Part no. 40-147



AC CABLE - EU Plug

AC Cable with EU plug only.

Suitable for:
MXTS 70/50, MXTS 40

2 year warranty.

Part no. 40-146



DC CABLE - 5M

5 metre DC cable including heavy duty clamps.

Suitable for:
MXTS 70/50

2 year warranty.

Part no. 56-759



CLAMPS - Red

Heavy duty replacement positive terminal clamp.

Suitable for:
MXTS 70/50

2 year warranty.

Part no. 40-143



CLAMPS - Black

Heavy duty replacement negative terminal clamp.

Suitable for:
MXTS 70/50

2 year warranty.

Part no. 40-142

MAXIMIZING BATTERY PERFORMANCE | WWW.CTEK.COM

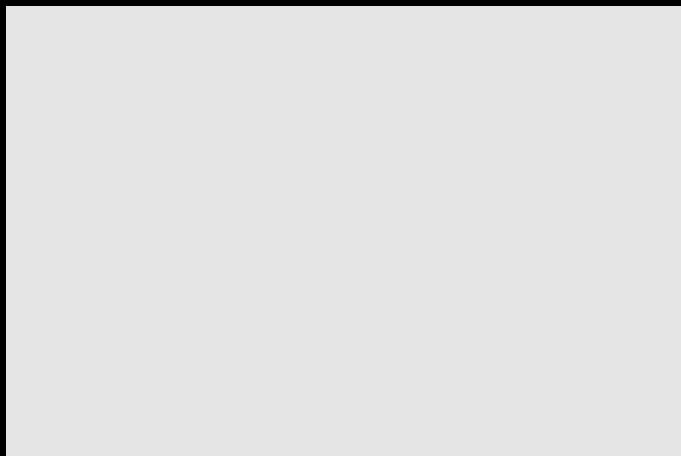

CTEK | **MAXIMIZING
BATTERY
PERFORMANCE**

CTEK SWEDEN AB
ROSTUGNSVÄGEN 3, SE-776 70 VIKMANSHYTTAN, SWEDEN
PHONE: + 46 225 351 80 | FAX: + 46 225 351 95
INFO@CTEK.COM | WWW.CTEK.COM